



FLOWSIC550

HIGH PRESSURE GAS FLOW METER
FOR NATURAL GAS DISTRIBUTION

Gas flow meters

SICK
Sensor Intelligence.

READY FOR THE FUTURE: WITH CUTTING-EDGE TECHNOLOGY FOR NATURAL GAS MEASUREMENT

Benefit from the latest technology for the ultimate in measurement accuracy: In 2012 SICK introduced the first ultrasonic gas flow meter for natural gas distribution. Now, thousands of installations later, we present the FLOWSIC550 - the new ultrasonic gas meter dedicated to high-pressure applications in natural gas distribution and midstream measurement systems. With the FLOWSIC550, SICK now expands its portfolio of ultrasonic gas flow meters and offers a suitable solution for small nominal diameters in the high-pressure range.

Four nominal diameters – and all easy to operate

Thanks to the use of ultrasound technology and the absence of mechanical components, the FLOWSIC550 offers a competitive advantage over turbine and rotary displacement meters. The FLOWSIC550 operates either in an energy self-sufficient configuration or with external power supply. When utilized in transfer and measuring stations, FLOWSIC550 ensures a continuous and blockage-free gas supply.

FLWSIC550: Simple, cost-effective installation and integration

The FLOWSIC550 is easy to install with only 3D required straight upstream and 2D required straight downstream pipe. The integrated and patented flow conditioner allows the use in most compact installations and fulfills accuracy requirements for Class 1. Therefore, it can easily be integrated in existing measuring installations.

Gas flow measurement and volume correction have the same goal: providing a precise measurement of the quantity of gas supplied. The FLOWSIC550 combines all functions into one device, thereby helping to save on installation costs and reducing the number of interfaces. The integrated volume corrector supports all typical correction algorithms, such as SGERG88, AGA 8 options e.g. DC92 Gross 1 & Gross 2, and AGA NX-19.

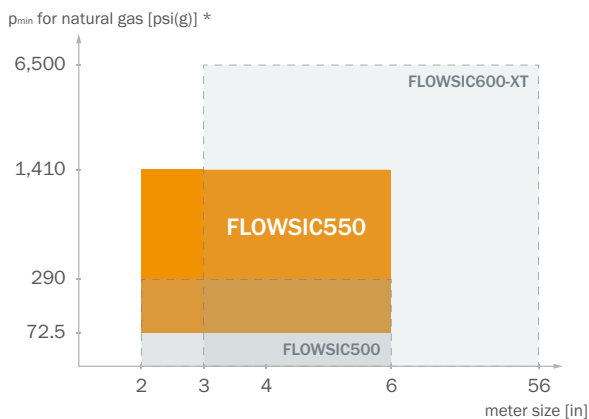

* operation with air at ambient pressure possible

FLWSIC550: Increasing efficiency in gas distribution

- Gas measurement of low volume applications at high pressures
- Custody transfer: gas distribution and transmission systems
- Town border stations and city gate stations
- Compressor fuel gas measurement
- High pressure industrial gas measurement
- Applications where a continuous gas supply must be ensured

FLOWGATE™ OPERATING SOFTWARE

- The FLOWgate™ user software offers a user-friendly and results-oriented solution for all life cycle management tasks of the FLOWSIC550.
- FLOWgate™, with its wizards for calibration, commissioning and device diagnostics, supports the almost maintenance-free operation of the gas flow meter and can also be used to remotely monitor the gas flow meter.
- The Device Manager shows all registered devices, and offers device grouping and a convenient data backup function. Thanks to the integrated database you can access the stored data anytime offline or online.
- The intuitive operation and multi-language support of FLOWgate™ makes the FLOWSIC550 gas flow meter easy to use.



Device Manager

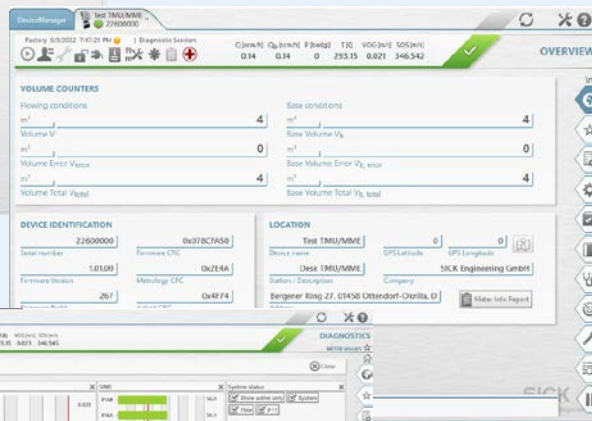

Meter values

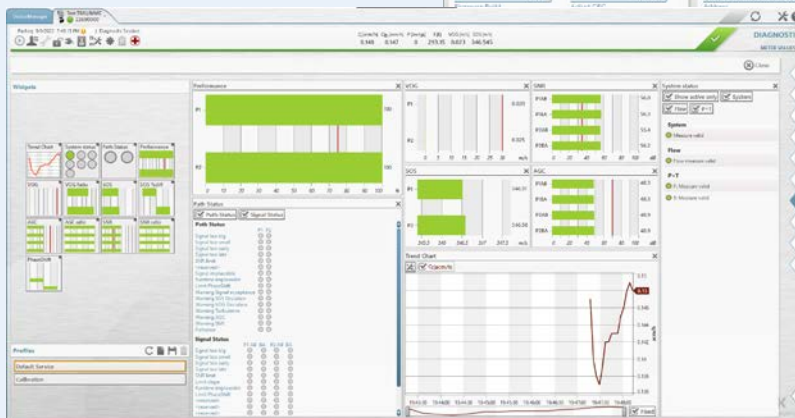

Overview

HIGH PRESSURE GAS FLOW METER FOR NATURAL GAS DISTRIBUTION



Product description

The cutting-edge technology for natural gas measurement: The new FLOW SIC550 ultrasonic compact gas meter from SICK ensures highly accurate metering for low volume at high pressures in gas distribution - a perfect addition to FLOW SIC500. In absence of mechanical moving parts, the FLOW SIC550 is a robust, fail-safe and low-maintenance device – allowing for a significant reduction in operating costs. It is overload-proof, accurate and

is monitored by an intelligent diagnostics system. FLOW SIC550 can easily be integrated into existing measuring stations. The FLOW SIC550 operates either in an energy self-sufficient configuration or in network operation. When utilized in transfer and measuring stations, FLOW SIC550 ensures a continuous and blockage free gas supply.

At a glance

- Rugged and time-proven ultrasound technology
- Diagnostics and permanent operational self-monitoring
- Durable and reliable without moving parts
- Compact meter installations
- Integrated volume correction
- Battery or intrinsically safe power supply
- Bluetooth Low Energy (BLE)

Your benefits

- Ultimate measurement certainty and safety of continuous gas supply
- Simple installation, compatible with turbine gas meters
- Reduction of installation costs due to integrated volume correction
- Easy Commissioning and data reading via FLOWgate™ (PC and App)
- Minimal operating costs due to being nearly maintenance-free
- Reliable even when the gas flow fluctuates (on/off applications)
- Self-sufficient operation

Fields of application

- Gas Measurement of low volume applications at high pressures
- Custody transfer: gas distribution, uni-directional storage, and transmission systems
- Town border stations and city gate stations
- High pressure industrial gas measurement
- Compressor fuel gas measurement
- Critical applications where continuous gas supply must be ensured



More information

Detailed technical data5
 Ordering information6
 Dimensional drawing7

→ www.sick.com/FLAWSIC550

For more information, simply visit the above link to obtain direct access to technical data, CAD design models, operating instructions, software, application examples, and much more.

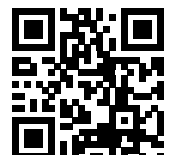

Detailed technical data

The exact device specifications and performance data of the product may deviate from the information provided here, and depend on the application in which the product is being used and the relevant customer specifications. Please contact your local SICK representative for information about the performance of the FLOWSIC550 for your application.

System

Measured values	Volume a.c., volume flow a.c., gas velocity In addition, for integrated volume correction: volume s.c., volume flow s.c.
Measurement principle	Ultrasonic transit time difference measurement
Measuring medium	Natural gas (dry, odorized), air
Measuring ranges	
Volume flow, a. c., 2"	88 ... 7,062 cfh
Volume flow, a. c., 3"	226 ... 17,660 cfh
Volume flow, a. c., 4"	upcoming
Volume flow, a. c., 6"	upcoming
Repeatability	≤ 0.1%
Accuracy	Accuracy class 1; maximum allowed error limits
Q_{\min} up to $0.08 Q_{\max}$	≤ ± 2%
$0.08 Q_{\max}$ up to Q_{\max}	≤ ± 1%
Diagnostic functions	Permanent monitoring of measured values
Gas temperature	-40 °F ... +158 °F
Operating pressure	
ANSI300 (ASME B16.5)	72.5 psi(g) 705 psi(g) for 158 °F 72.5 psi(g) 740 psi(g) for -40 ... 100 °F
ANSI600 (ASME B16.5)	72.5 psi(g) 1,410 psi(g) for 158 °F 72.5 psi(g) 1,480 psi(g) for -40 ... 100 °F
	Pressure ranges valid for natural gas, meter operation possible at ambient pressure for air
Sealing surface	Raised faced, stock finished
Ambient temperature	-40 °F ... +158 °F
Conformities	OIML R 137-1&2:2012 AGA 9, 2022
Ex approvals	CSA Class I Division 1, Groups C, D T4 Ex ia [ia Ga] IIB T4 Gb Class I, Zone 1 AEx ia [ia Ga] IIB T4 Gb
Enclosure rating	IP66
Digital outputs	2x Pulse and Status (HF with fmax = 2kHz, LF with fmax = 10 Hz) 2x RS485, external powered
RS485 protocol	Modbus RTU
Interface	Wired M12/USB Adapter or Bluetooth Low Energy (BLE) 4.2 Adapter
Material in contact with media	Low Temperature Carbon Steel
Mounting	Horizontal or vertical installation with 3D straight inlet and 2D straight outlet piping
Electrical connection	Intrinsically safe supply 8 V ... 16 V DC, max. 50 mA Battery powered (life time over 5 years)
Dimensions	see dimensional drawings

Weight	2"	44 lbs
	3"	88 lbs

VOLUME CORRECTION

Accuracy	Conversion factor C	Accuracy class 0.5 Maximum permitted error limits of $\leq \pm 0.5\%$ (at reference conditions)
Correction method		PTZ
Compressibility		SGERG88 AGA 8 Gross method 1 AGA 8 Gross method 2 AGA 8 DC92 AGA NX-19 AGA NX-19 mod. GERG91 Fixed value
Data archives		Measurement period archive (6,000 entries) Daily archive (600 entries) Monthly archive (25 entries)
Log books		Event log book (1,000 entries) Parameter log book (250 entries) Metrology log book (100 entries) Gas parameter log book (150 entries)
Pressure sensor	Gauge pressure	0... 1,015 psi(g) 0... 1,500 psi(g)
Temperature sensor		PT1000 class A

Custody transfer measuring ranges Ordering information

Our regional sales organization would be happy to advise you on what device configuration is best for you.

Dimensional drawing (Dimensions in inch)

Temperature sensor

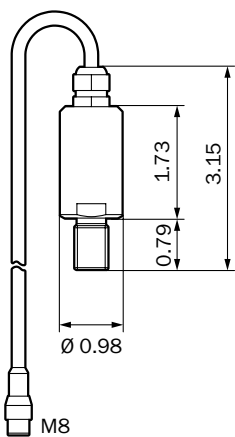

Temperature sensor

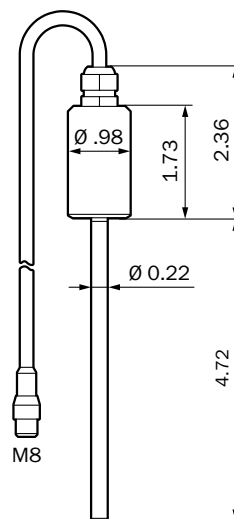

FLWSIC550

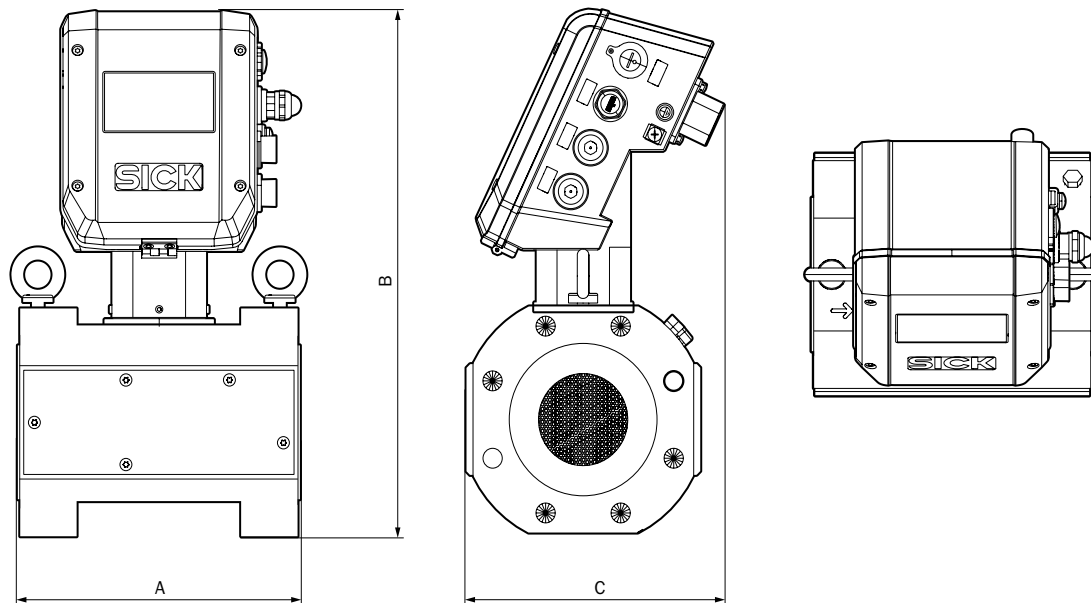

Nominal size	Dimensions [inch]		
	A	B	C
2"	5.9	16.73	8.66
3"	9.45	16.73	8.66

Pressure loss

FLWSIC550 causes a typical pressure loss of:

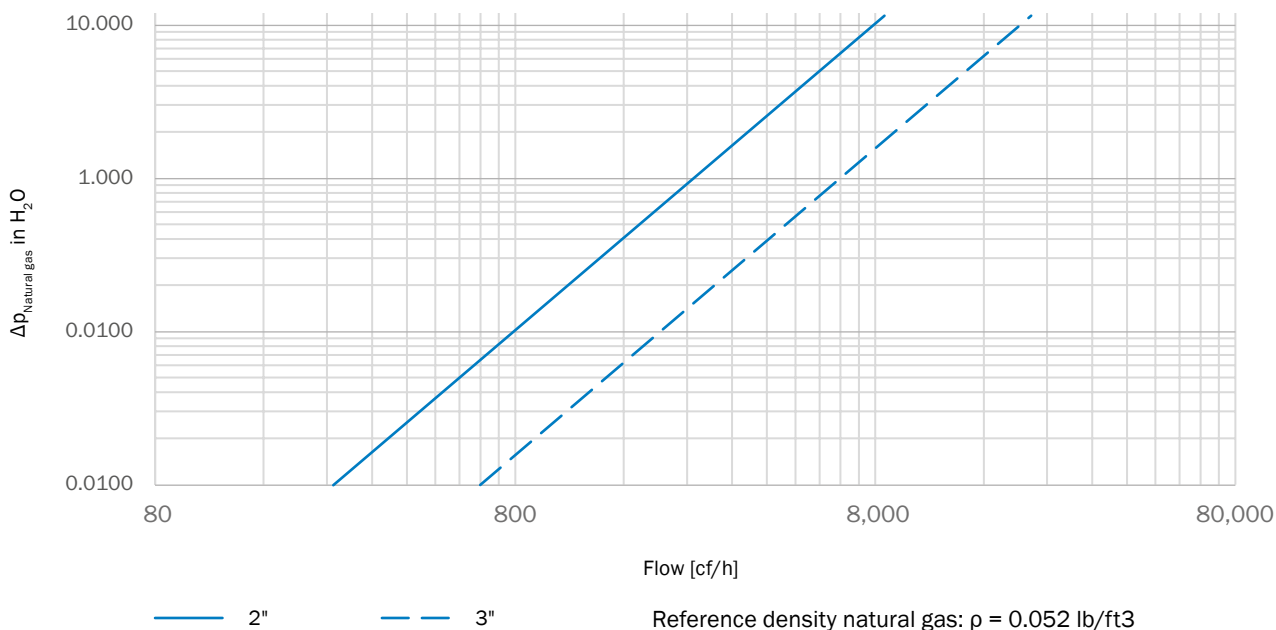

SICK AT A GLANCE

SICK is a leading manufacturer of intelligent sensors and sensor solutions for industrial applications. With more than 11,000 employees and over 50 subsidiaries and equity investments as well as numerous agencies worldwide, SICK is always close to its customers. A unique range of products and services creates the perfect basis for controlling processes securely and efficiently, protecting individuals from accidents, and preventing damage to the environment.

SICK has extensive experience in various industries and understands their processes and requirements. With intelligent sensors, SICK delivers exactly what the customers need. In application centers in Europe, Asia, and North America, system solutions are tested and optimized in accordance with customer specifications. All this makes SICK a reliable supplier and development partner.

Comprehensive services round out the offering: SICK LifeTime Services provide support throughout the machine life cycle and ensure safety and productivity.

That is “Sensor Intelligence.”

Worldwide presence:

Australia, Austria, Belgium, Brazil, Canada, Chile, China, Czech Republic, Denmark, Finland, France, Germany, Great Britain, Hungary, Hong Kong, India, Israel, Italy, Japan, Malaysia, Mexico, Netherlands, New Zealand, Norway, Poland, Romania, Russia, Singapore, Slovakia, Slovenia, South Africa, South Korea, Spain, Sweden, Switzerland, Taiwan, Thailand, Turkey, United Arab Emirates, USA, Vietnam.

Detailed addresses and further locations → www.sick.com